

communications for life



619SRI

smart radio interface



omnitronics

619SRI

smart radio interface



The 619SRI offers the perfect affordable interoperability solution to communications integrators.

In this day and age, providing interoperability has never been so important. However, lack of any standard interface on radio equipment has made interconnection of radios and other audio sources a nightmare. It is not uncommon to have systems with multiple VHF, UHF, microwave and SSB equipment requiring complex interconnections to allow cross band and inter-service communications. To add to this complexity, operation managers often want to change how systems are configured for maintenance or operational reasons.

OMNITONICS has solved this problem with the 619SRI (Smart Radio Interface). The 619SRI is a third generation product that has evolved from the successful and proven line of audio bridges. The 619SRI provides the communications integrator with a number of powerful features that can be used to add value to both fixed and dynamic radio networks.

The 619SRI is an eight-port radio communications and configuration hub that is designed to provide cost effective interoperability between radios from different manufacturers and with varying signalling requirements. Using Omnitronics' proprietary technology, "DHC" (Dynamic Hub Configuration), the 619SRI brings together CTCSS, in-band keying, VOX, SELCAL and DTMF with a number of programmable configuration overlays. This provides users with the ability to dynamically configure radio networks to suit operational requirements and, through a Windows graphical user interface, makes radio interconnection easier than ever before.

quality

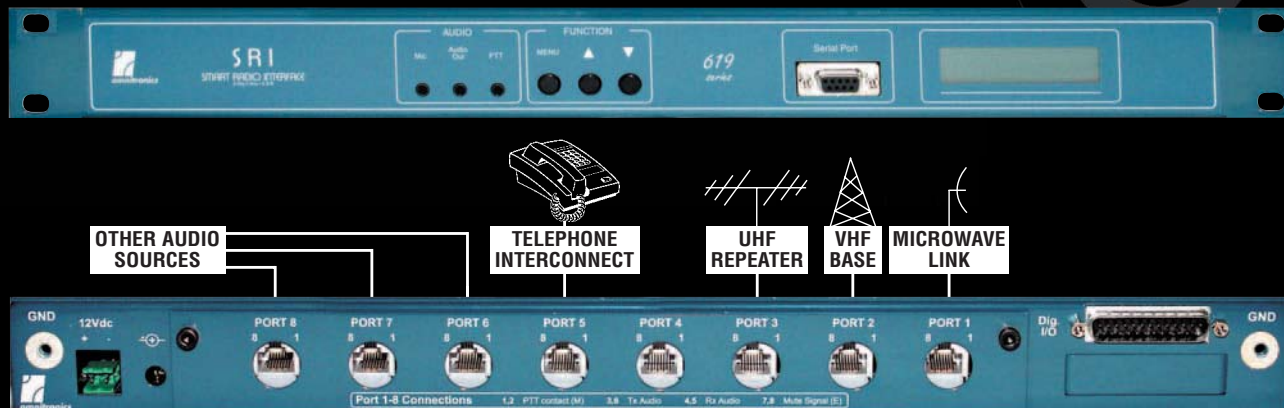

Applications

The 619SRI is designed to be used in many applications. Some of the most common include:

- Interconnecting disparate radios.
- Subdividing radio networks for frequency optimisation.
- Creating separate voice and data paths through repeaters.
- Optimisation of link traffic flow and fast link keying.
- System splitting & merging on-demand.
- Remotely adjusting levels and keying times in standard and voting networks.
- Converting between various keying/squelch mechanisms.

Features

There are many hardware and software features that give this product its advanced capabilities, including:

- Single 1RU enclosure with eight analog 4-wire E&M ports; all with opto-isolated inputs, relay isolated outputs and with contact, voltage and switched power options.
- Transformer isolated line audio with digital gain control.
- Independent signalling encoders/decoders on all eight ports, supporting CTCSS, inband “keying” tones and vox operation.
- Simultaneous signal detection and generation on each port.
- SELCAL and DTMF remote control.
- Eight programmable configurations that provide control of the basic Mute to PTT linking. Six of these are programmable overlays that can be invoked to dynamically make or break link paths. *DHC* technology allows this to occur as a result of a digital input, CTCSS tones, inband tones, DTMF or SELCAL.
- Software options that support fast CTCSS keying, soft CTCSS key-off and PTT tail tones.
- Device re-configuration through the Windows-based *SRI Graphical User Interface*. This can be carried out either directly using an RS-232 connection or remotely using RS-485, a radio (V.23 modem) or a GSM modem.
- Real-time clock that allows the scheduling of heartbeat/voting tones.
- Auxiliary inputs and outputs for monitoring and control applications.
- LCD panel for status and diagnostics.
- 12 to 24VDC operation.

Benefits

- Provides interoperability across private & public land mobile radio.
- Reduces the cost of adding additional hardware and increases system flexibility.
- Reduces traffic at repeater sites thereby improving system performance.
- Allows networks to be re-configured to meet peak or after hours traffic demands.
- Eliminates long delays in multi-hop links, thereby increasing performance.
- Reduces the time required to perform maintenance and improve the performance of voting networks.

Quite simply, the 619SRI is the most cost effective method of interconnecting multiple radios on the market.

For more technical information on the 619SRI or to download the 619SRI applications handbook, please visit the Omnitronics web site at www.omnitronics.com.au

Operation Overview

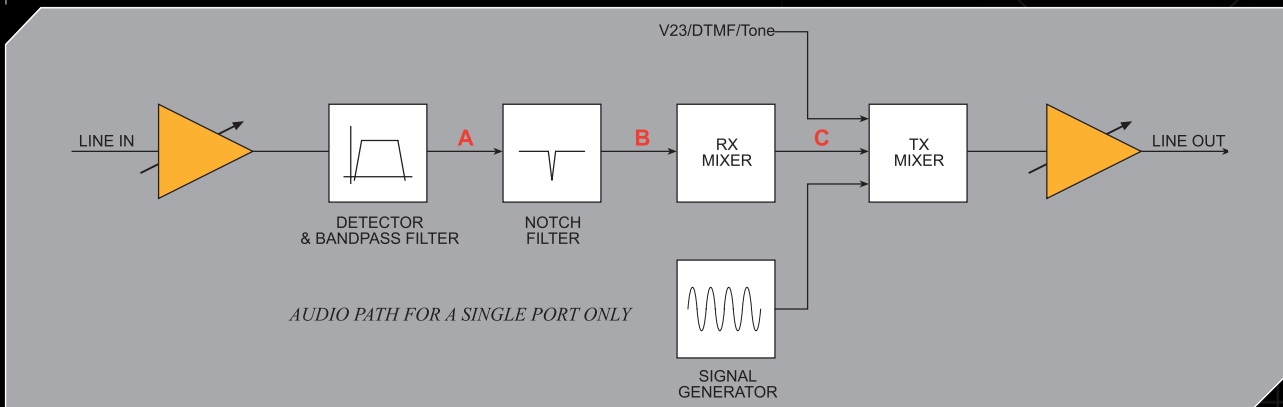

System Overview

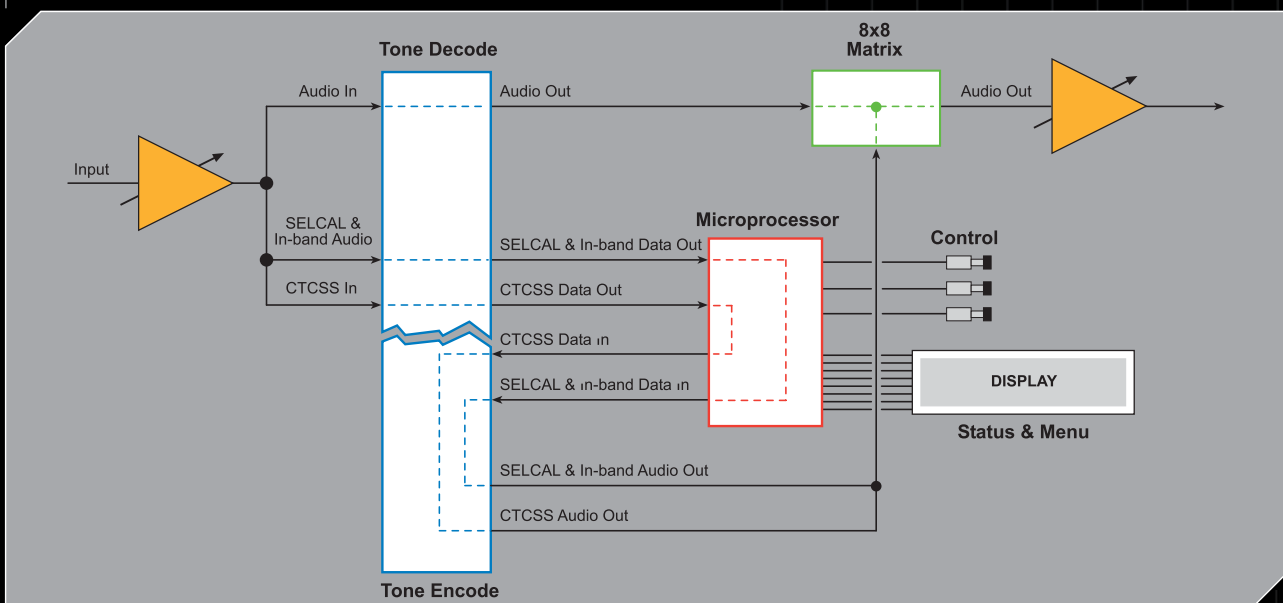

619SRI

smart radio interface

Quite simply, the 619SRI is the most cost effective method of interconnecting multiple radios on the market.

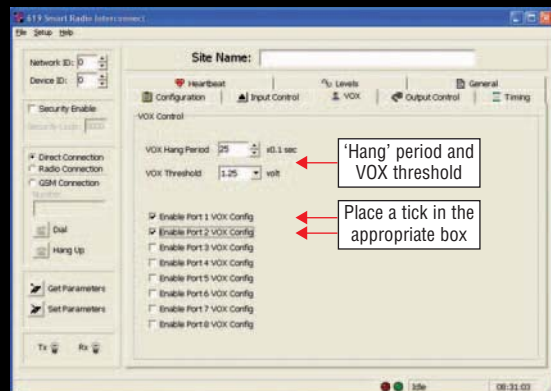
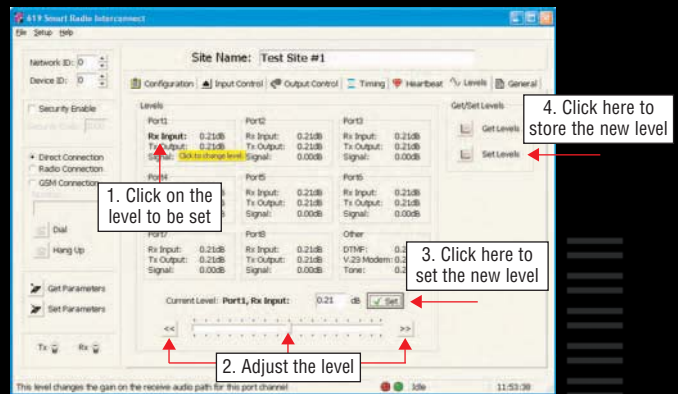
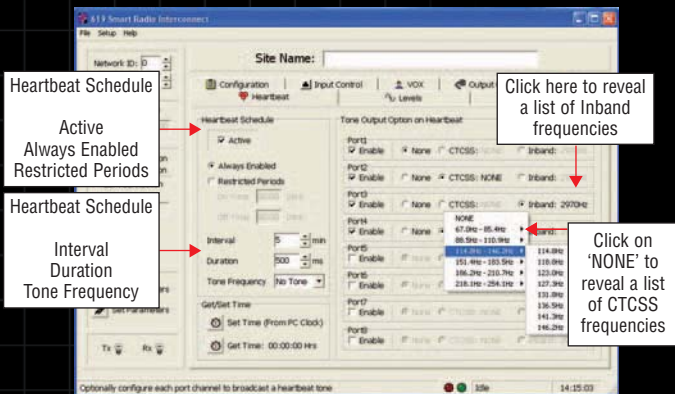
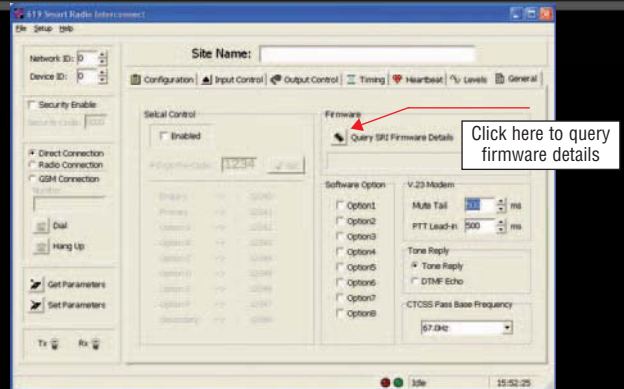
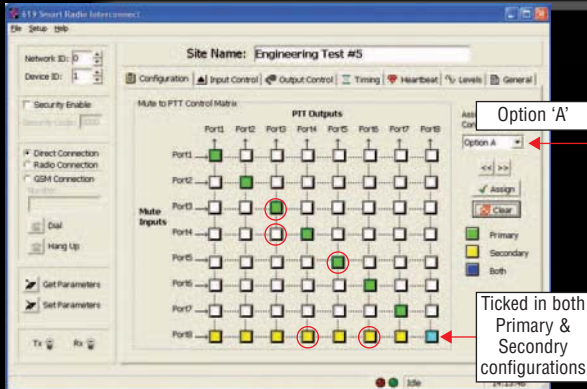

A selection of configuration software screen shots.

Most parameters can be configured and monitored from the front panel using the back lit LCD panel and push button switches.





Applications of the 619 SRI Smart Radio Interface

Applications Summary For The Network Designer

	<i>Application</i>	<i>Features Used</i>	<i>Benefits</i>
1	Interconnect different communication mediums	<ul style="list-style-type: none"> → 4-wire E&M ports with isolated inputs and outputs → Configurable inputs & outputs → Independent subaudible and inband tone transceivers → COS or tone detection 	<ul style="list-style-type: none"> → Provides interoperability across private & public land mobile radio ie join Police to Fire to Ambulance services etc
2	Subdivide radio networks	<ul style="list-style-type: none"> → Programmable bridging configurations → Configuration switching (linking & unlinking) using SELCAL or DTMF → Automatic status tones on the tail of linked transmissions 	<ul style="list-style-type: none"> → Reduces the cost of additional hardware → Reduces traffic at repeater sites thereby improving system utilisation → Increases system flexibility
3	Voice & Data Segregation	<ul style="list-style-type: none"> → Programmable CTCSS detection of dual frequencies → CTCSS steering through dynamic switching → CTCSS generation dependant on the input source 	<ul style="list-style-type: none"> → Reduces hardware costs by allowing voice and data units to share the same repeater network
4	Optimisation of Link Traffic Flow	<ul style="list-style-type: none"> → Programmable CTCSS detection of dual frequencies → CTCSS steering through dynamic switching → CTCSS generation dependant on the input source → Selective configurations 	<ul style="list-style-type: none"> → Reduces traffic at repeater sites thereby improving system performance
5	System Splitting On-demand	<ul style="list-style-type: none"> → Remote configuration selection through SELCAL or DTMF → Split System timer feature for automatic reversion to the Primary Configuration 	<ul style="list-style-type: none"> → Radio network can be re-configured to meet peak traffic demands
6	System Merging On-demand	<ul style="list-style-type: none"> → Remote configuration selection through SELCAL or DTMF 	<ul style="list-style-type: none"> → Radio networks can be merged for after hours "night switching", eliminating the need for operator intervention
7	Fast Link Keying	<ul style="list-style-type: none"> → Fast CTCSS output on COS → Programmable tone detect period → Programmable false trigger lockout 	<ul style="list-style-type: none"> → Eliminates long delays in multi-hop links, thereby increasing performance
8	Normalising Repeater Key-up Times	<ul style="list-style-type: none"> → Programmable delays on PTT output 	<ul style="list-style-type: none"> → Ensures that repeater sites are synchronised, thereby improving the performance of voting networks
9	System Tuning in Voting Networks	<ul style="list-style-type: none"> → Remotely adjustable line input and output levels → 619 SRI's are addressable 	<ul style="list-style-type: none"> → Save time by allowing voting networks to be tweaked remotely
10	Conversion of Keying/Squelch Mechanisms	<ul style="list-style-type: none"> → Independent subaudible and inband tone transceivers → Programmable detection and generation of subaudible 	<ul style="list-style-type: none"> → Improves network flexibility → Provides interconnection between different equipment
11	Shared Radio Telephone Access	<ul style="list-style-type: none"> → Remote configuration selection through SELCAL or DTMF 	<ul style="list-style-type: none"> → Reduces the cost of telephone access by making it available to multiple networks

Subdivision and linking of disparate radio systems

Application 1

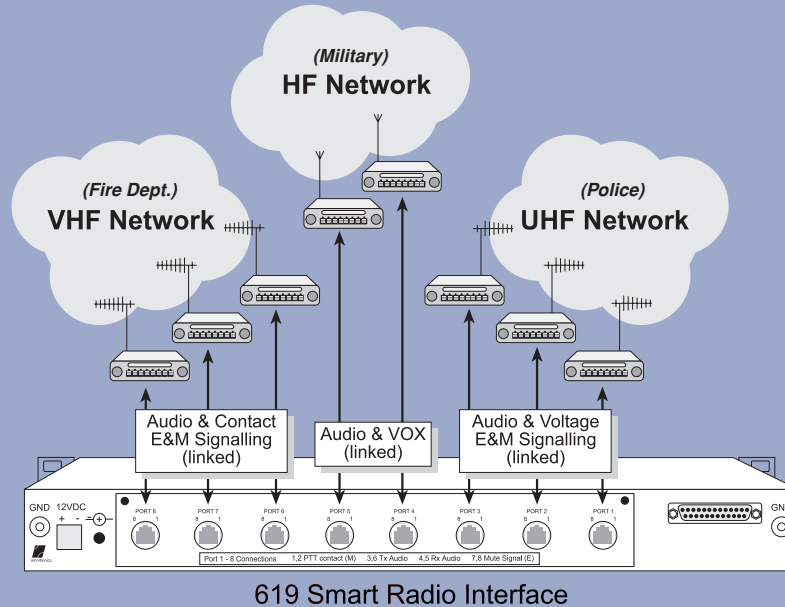

619 Smart Radio Interface

The 619SRI can act as a hub for radio networks utilising DHC, (Dynamic Hub Configuration), which allows the operator to dynamically change the system by sending a remote command sequence.

Conversion of keying/squelch mechanisms to control radio networks with multiple groups

Application 2

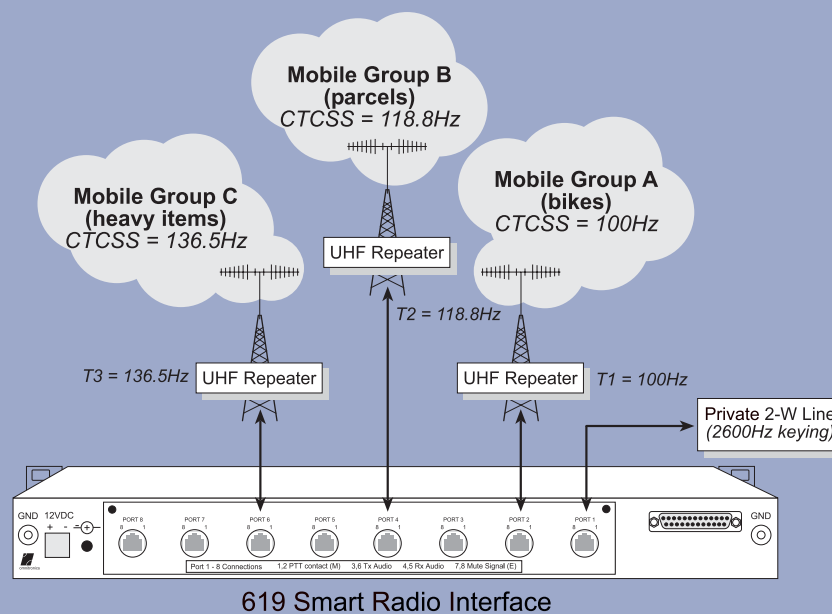

619 Smart Radio Interface

In this application the dispatch operator can command the 619SRI to cross link mobiles from different groups by controlling the CTCSS conversion facility in the bridge.

Specifications

→ POWER SUPPLY

Voltage +11VDC to 28 VDC.
Current 120mA typical (max at 12V).

→ SIGNAL INTERFACE

The 'E' lead input (+5VDC to +30VDC) can be configured to be isolated and polarity independent.

The 'M' lead output relay contact limit is 30VDC or 1A (maximum power rating is 30W). If using the internal supply from the 619/15 board, the current should be limited to 20mA.

The front panel PTT is a 'contact' input and is a closed contact when active.

→ DIGITAL INTERFACE (DB25 CONNECTOR)

Relay outputs – the relay contact limit is 30VDC or 1A (maximum power rating is 30W).

Digital inputs are +5VDC to +30VDC and are isolated and polarity independent.
Analogue inputs are 0V to +10V.

→ AUDIO INTERFACE (INPUT LEVELS)

-27dBm to +12 dBm for voice.

Tone detect levels for an input gain of 0 are set to -21dBm.

→ SUB-AUDIBLE TONE

At 67Hz -27 to 0dBm.
At 254Hz -27 to +4dBm.

→ IN-BAND TONE

-25dBm to +4dBm (-40dBm with input gain set to maximum).

→ MODEM

-30dBm to +4dBm.

→ DTMF

-27dBm to +4dBm.

→ SELCAL

-30 to +4dBm.

→ MIC INPUT ON FRONT PANEL

For -6dBm output, the gain allows the input to be from 35mVpp to 4.8Vpp.
Maximum gain is 34dB.

→ OUTPUT LEVELS

-27dBm to +4 dBm for voice.

Signalling tone levels are independent of voice channel levels.

CTCSS/Inband Tone -28dBm to +3dBm.

Modem -30dBm to +4dBm.

DTMF -30dBm to +4dBm.

Hi/Lo Test Tone -26dBm to +2dBm.

The in-band tone, relative to voice level, can be from 0 to 12dB in 0.4dB steps and -40dB. For a signal received on one input channel and transmitted on another channel, the differential in level is -2dB, ie the output can be 20dB less or +15dB greater than the input.

The monitor output on the front panel (into 2k Ω load for -6dBm input) is 10mVpp to 9.8Vpp.

→ FREQUENCY RESPONSE

The frequency response is for a signal received on one input and transmitted on another, ie it is the complete response of the bridge.

→ FREQUENCY RESPONSE WITH NO IN-BAND SIGNALLING

The response is within 3dB from 300 to 5kHz.

The response is within 1dB from 350 to 3.7kHz.

For an in-band filter there will be a 3dB decrease in level at $\pm 8\%$ of the filter frequency.

There will be a 10dB decrease at $\pm 5\%$ of the filter frequency.

The tone detect window is $\pm 1.7\%$ of the filter frequency.

Input to output tone isolation is better than 50dB.

Cross-talk between channels is better than -60dB.

Distortion for a signal received on one input and transmitted on another is 0.25% (-50dB).

→ WEIGHT AND DIMENSIONS

1.7kg (unpacked).

H 44mm (1RU), L 484mm (19" subrack standard), D 265mm.



INTERNATIONAL OFFICE:

301 Coronation Drive, Milton, QLD 4064, Australia
Tel: +61 7 3369 5733 Fax: +61 7 3369 5799
E-mail: sales@omnitronics.com.au
Internet: www.omnitronics.com.au

Authorized American Distributor:

TERRYCOMM

4155 Dow Rd. Unit N
Melbourne, FL USA 32934
Tel: 321-253-6067 Fax: 321-253-9529
www.terrycomm.com